

Technical Data



0905
DoP0283
DoP0284

EN54-18:2005 + AC: 2007

	BWEXTR24V	BWEXTR230V
Operating Characteristics		
Operating Voltage	18V – 22V	
Alarm Voltage	30.7V – 32.4V	
Quiescent Current	130 µA Nom	
Alarm Current	200 µA Nom	
Contact Ratings		
Sets of contacts	1	
Contact Type	Single pole changeover	
Contact Rating	1A @ 24VDC	3A @ 230VAC
Quiescent Current	130 µA Nom	
Environmental		
Operating Temperature	-10°C to + 55°C	
Humidity (Non Condensing)	93%RH	
Standards		
Standards	EN54:Pt18	
Compatibility		
Compatibility	Suitable for use with BiWire Ultra Panels only	
Physical Characteristics		
Dimensions	180x130x60mm	
Weight	0.5kg	
Ingress Protection	IP66	

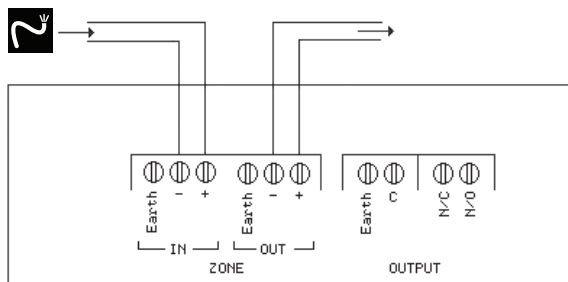
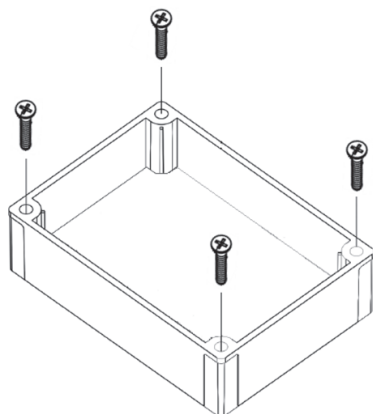

Installation

1. Remove the lid from the back box.
2. Unclip the PCB from the mounting pillars (to prevent damage during drilling).
3. Remove the mounting plate via the two screws (so you can gain access to the base of the back box).
4. Mark on the back box where the glands will be fitted, making sure there is sufficient space between glands so they can be tightened properly.
5. Using the appropriate sized cutting drill for the gland size used, drill out the marked gland points on the back box.
6. Fit the glands to the newly drilled holes in the back box.
7. Drill the holes in the wall to match the holes in the back box (see picture below).
8. Screw the back-box in position (see picture below).
9. Screw the mounting plate back into the back box.
10. Clip the PCB into the mounting pillars on the mounting plate.
11. Pass the wires through the glands and secure to the PCB as outlined in the wiring instructions.
12. Secure the lid to the back box.

Wiring Instructions

1. Connect the wires from the Panel (if first device on the zone) or from the adjacent device on the zone to the "IN" terminals.
2. If there are devices after the relay unit then connect the wires from the next device to the "OUT" terminals.
3. If the relay unit is the last device on the zone then the EOLM-3 must be connected to the "OUT" terminals, and can be housed inside the relay enclosure.
4. Wire the external equipment to either the C and N/C (Normally Closed) or C and N/O (Normally Open) depending on the switching state of the equipment. Please refer to the external equipment documentation for correct switching polarity.

Notes

1. Relay contacts will operate if any zone receives a fire signal, even if relay is connected to a different zone to the one that is triggered.
2. If class change OR Non-Latching zone is used on the Ultra or Flexi panels then ALL relays on ALL zone operate and require a panel reset to clear this condition.
3. BWEXTR24V is only suitable for switching 24V loads.
4. BWEXTR230V is only suitable for switching mains rated loads.
5. If the relay module is fitted at the far end of the zone wiring, then the EOLM-3 must be wired to the zone out terminals.
6. There are no serviceable parts so no maintenance procedures apply.



Powering Business Worldwide

Eaton Electrical Systems Ltd.
Wheatley Hall Road
Doncaster
DN2 4NB
TEL: +44 (0) 1302 303303
FAX: +44 (0) 1302 367155

Eaton
EMEA Headquarters
Route de la Longeraie 7
1110 Morges, Switzerland
Eaton.eu
TEL: +44 (0) 1302 321541
FAX: +44 (0) 1302 303220
Firesales@eaton.com
Firetechsupport@eaton.com

© 2019 Eaton
All Rights Reserved
Eaton is a registered trademark.

All trademarks are property
of their respective owners.
www.Eaton.com